

# UKANA

MÉRIDA

El nuevo complejo de Grupo ORVE conformado por 239 departamentos, distribuidos en 4 torres residenciales, con amenidades para todos sus residentes que evocan el confort de un lugar en completa tranquilidad.

Los departamentos se encuentran divididos en 4 modelos para adecuarse a los distintos perfiles de clientes y sus necesidades.

# UKANA

MÉRIDA

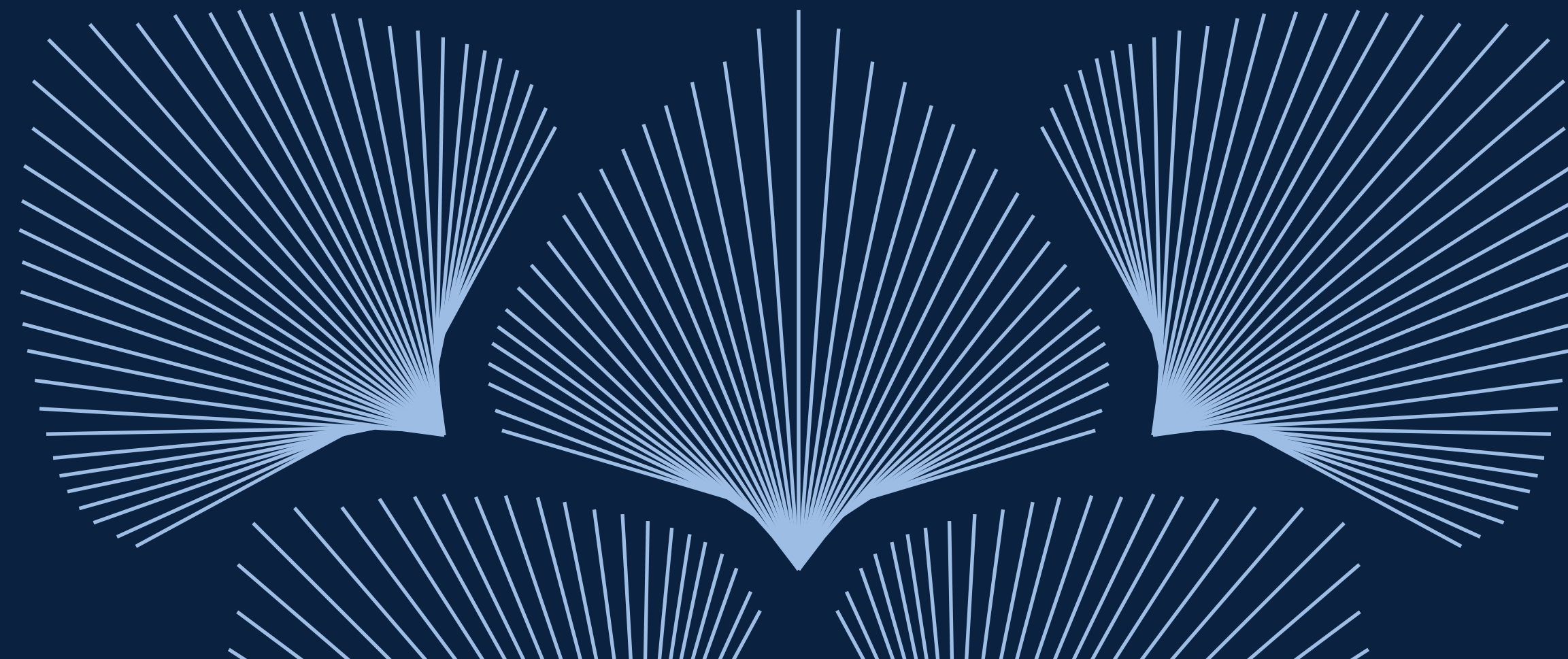

# Todo lo que necesitas para una vida en equilibrio en cuestión de minutos

## Centros comerciales

		
City Center	7 min.	5.1 km.
Plaza The Harbor	9 min.	8.6 km.
Plaza la Isla	6 min.	5.3 km.
Galerías Mérida	12 min.	8.4 km.
Gran Plaza	13 min.	10 km.



## Universidades

		
Universidad Marista	7 min.	7.2 km.
UVM	10 min.	10 km.

## Hospital

		
El Faro del Mayab	5 min.	4.2 km.
Star Médica	12 min.	5.6 km.

## Residenciales

		
Residencial Kenúa	1 min.	500 mt.
Residencial Kinish	1 min.	800 mt.
Residencial Julieta	1 min.	1.1 km.
Residencial Silvano	1 min.	1.2 km.
Citadella	2 min.	1.5 km.
Residencial Cocoyoles	6 min.	4.5 km.
Cabo Norte	8 min.	5.7 km.

## Otros

		
Periférico	3 min.	2.9 km.
Orión Business	6 min.	4.6 km.

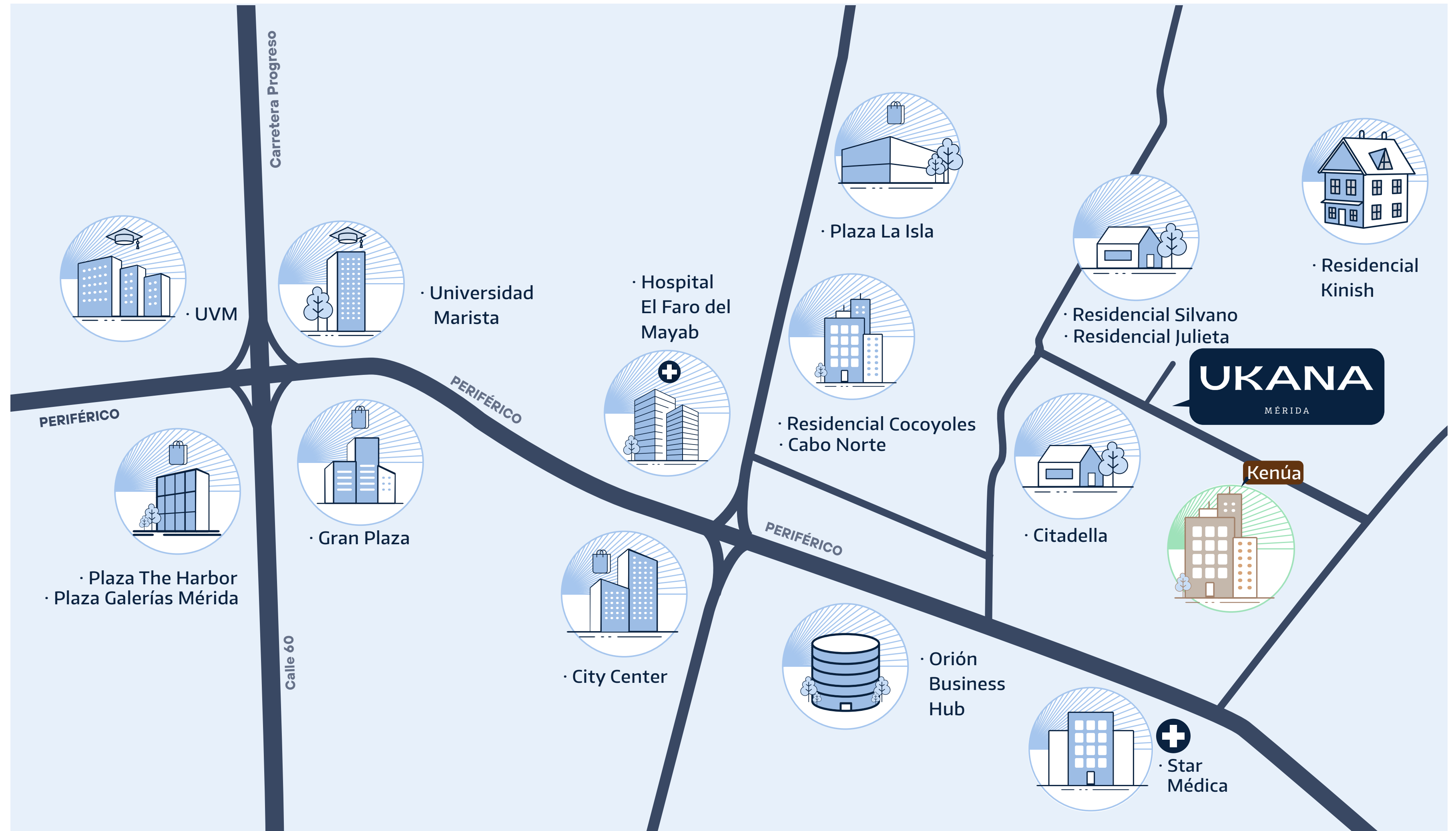



# Master Plan

- 1.- Torre 1 | 31 Departamentos
- 2.- Torre 2 | 60 Departamentos
- 3.- Torre 3 | 71 Departamentos
- 4.- Torre 4 | 83 Departamentos
- 5.- Casa Club
- 6.- Pet Park
- 7.- Acceso
- 8.- Área Comercial
- 9.- Elevador | Torre 2

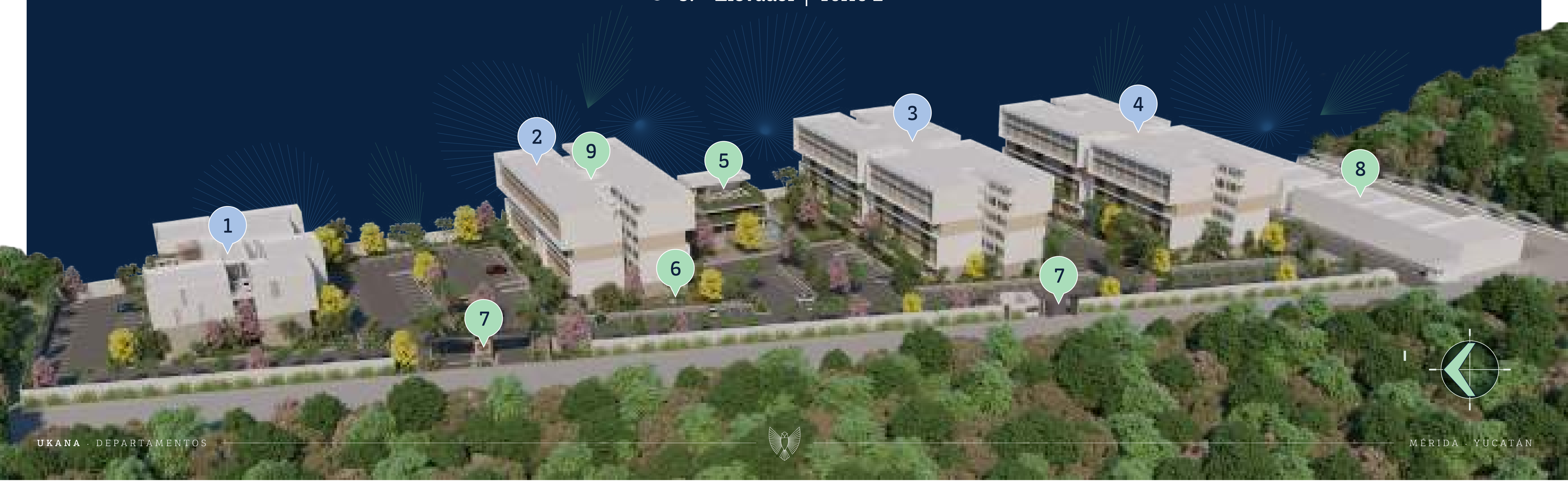



# Amenidades para todos los residentes



Pet Park

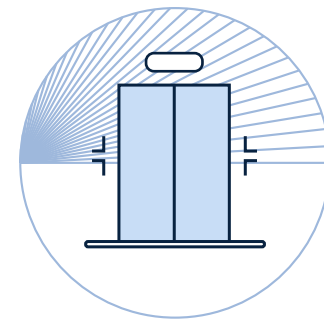

Elevador  
en Torre 2

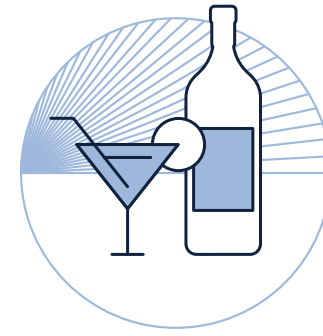

Rooftop Bar

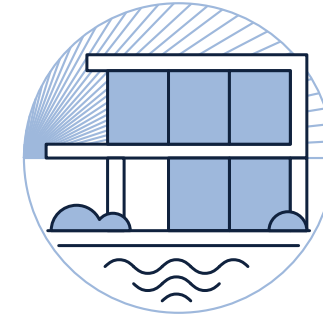

Casa Club

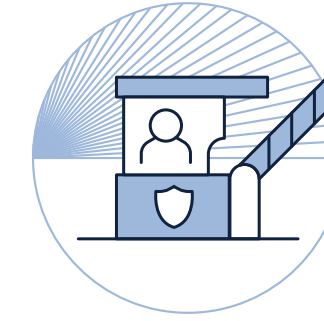

Acceso Controlado

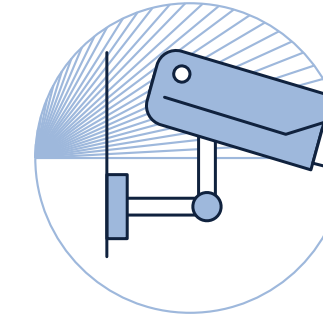

Seguridad 24/7

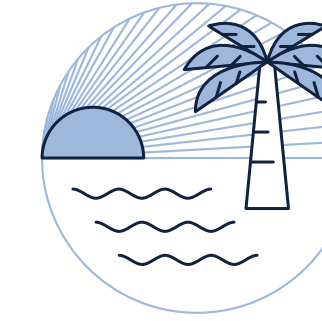

Club de Playa







Casa Club

Segundo Nivel

Primer Nivel

Planta Baja

## Una Casa Club muy especial

**Ukana** mantiene un equilibrio perfecto entre confort y privacidad ofreciendo a cada uno de sus residentes acceso exclusivo a una Casa Club ubicada dentro del mismo proyecto, la cual está totalmente equipada y acondicionada con áreas pensadas para satisfacer las necesidades de sus habitantes.







## Planta Baja

- Kids Club
- Alberca
- Canal de nado
- Terrazas
- Área de cocina
- Área para asadores
- Asoleadero
- Baños

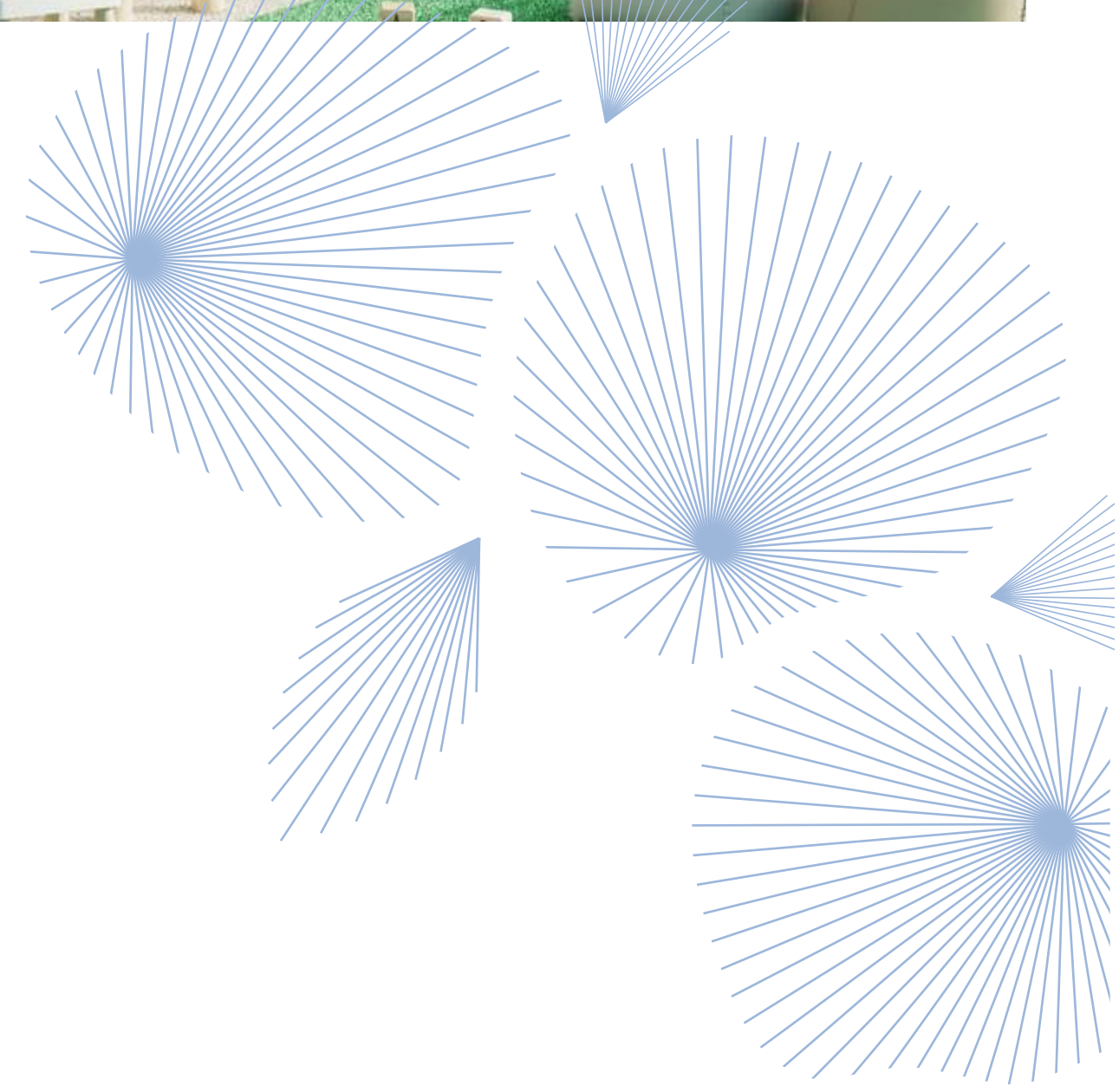



Gimnasio

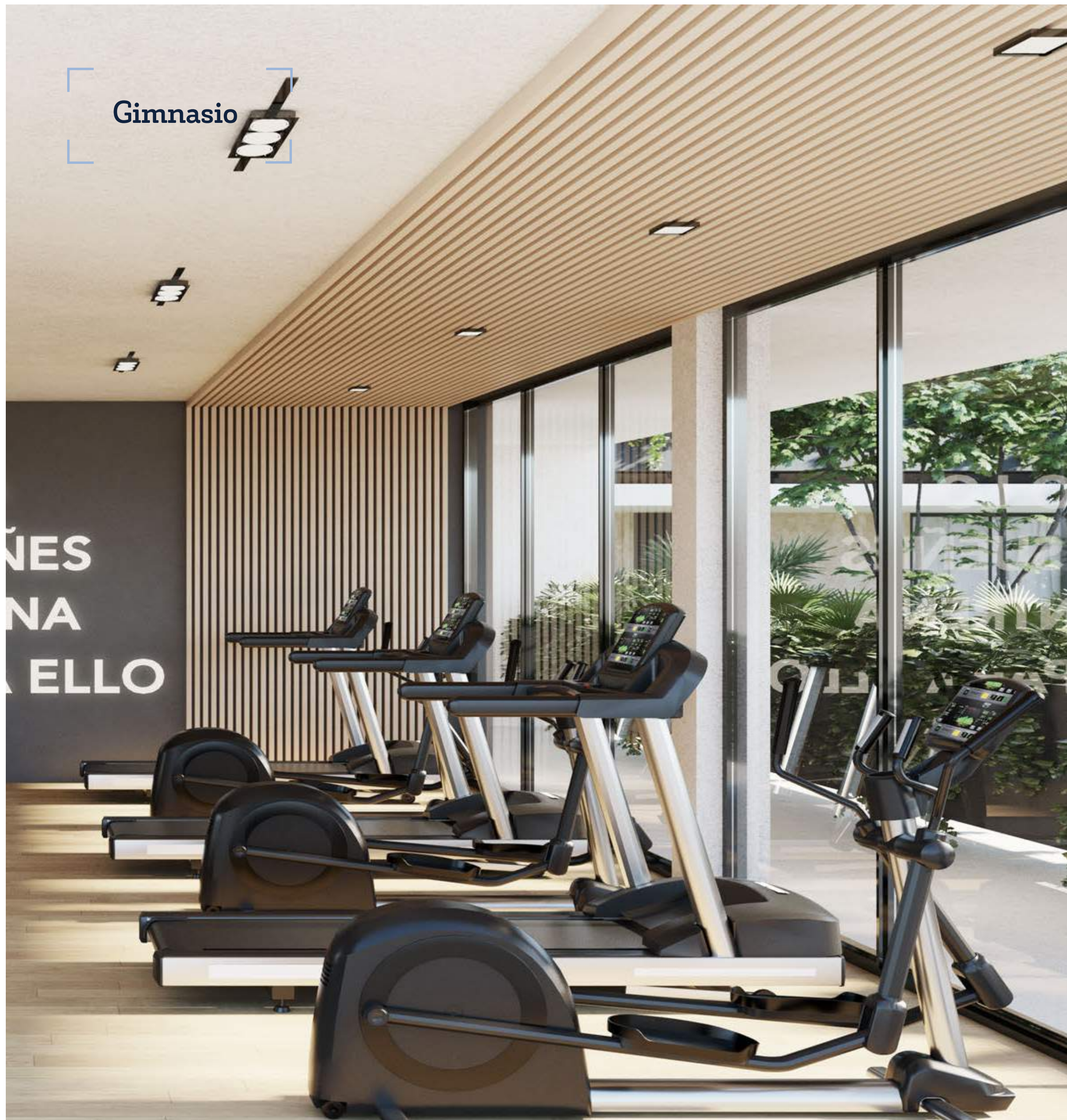

## Primer Nivel

- Gimnasio
- Lockers
- Baños
- Sports bar

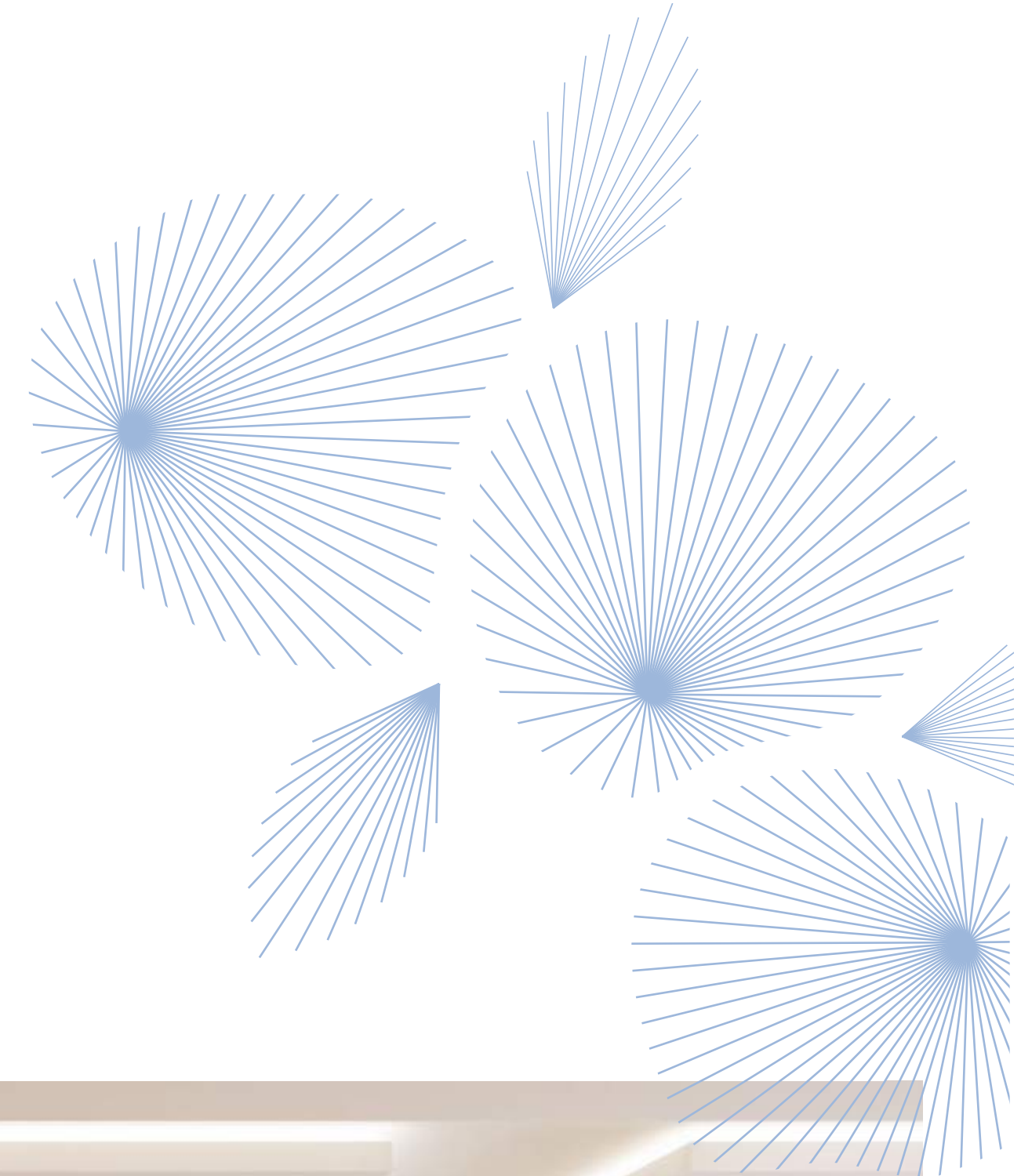

Sports Bar





Rooftop



## Segundo Nivel

- Rooftop
- Barra
- Baños
- Espacio para almacenamiento







Acceso







Rooftop





# Invertir con Grupo ORVE te da aún más

Al adquirir un proyecto con nosotros también obtendrás privilegios adicionales, reservados exclusivamente para nuestros clientes.

Entre ellos, contarás con acceso al **Club de Playa ORVE** ubicado como parte de la **Zona Esmeralda de la Península de Yucatán**, el cual contará con amenidades tipo resort como:

- Alberca
- Pool Bar
- Spa
- Kids Club
- Restaurante
- Snack Bar
- Terraza
- Área de hamacas
- Asoleadero
- Camas balinesas
- Baños con regaderas
- Lockers y vestidores
- Renta de equipos no motorizados
- Regaderas al aire libre
- Rooftop con vista al mar
- Cine al aire libre
- Área de fogatas
- Actividades acuáticas



¡Realiza un recorrido virtual!

Haz clic aquí





# UKANA

MÉRIDA

## Acabados

- Pisos cerámicos formato 60 x 60
- Cancelería de aluminio en ventanas
- Puertas de madera
- Cocina integral con gavetería inferior
- Parrilla eléctrica
- Muebles de baño de excelente calidad

## Casa Club de 616.47m<sup>2</sup> con dos niveles y un Rooftop

- **Planta Baja:** Kids Club, terraza techada y al aire libre, asoleadero, áreas de cocina, asadores y baños; alberca y canal de nado
- **Primer nivel:** gimnasio, lockers, baño para hombres y mujeres, sports bar y terrazas
- **Rooftop:** barra, mesas, sillas, baño de hombre y mujeres; bodega
- **Pet Park**



## Servicios

- Sistema de drenaje condensados
- Instalaciones hidráulicas y sanitarias, con grifos
- Instalación eléctrica en media y baja tensión, iluminación tipo LED en áreas comunes





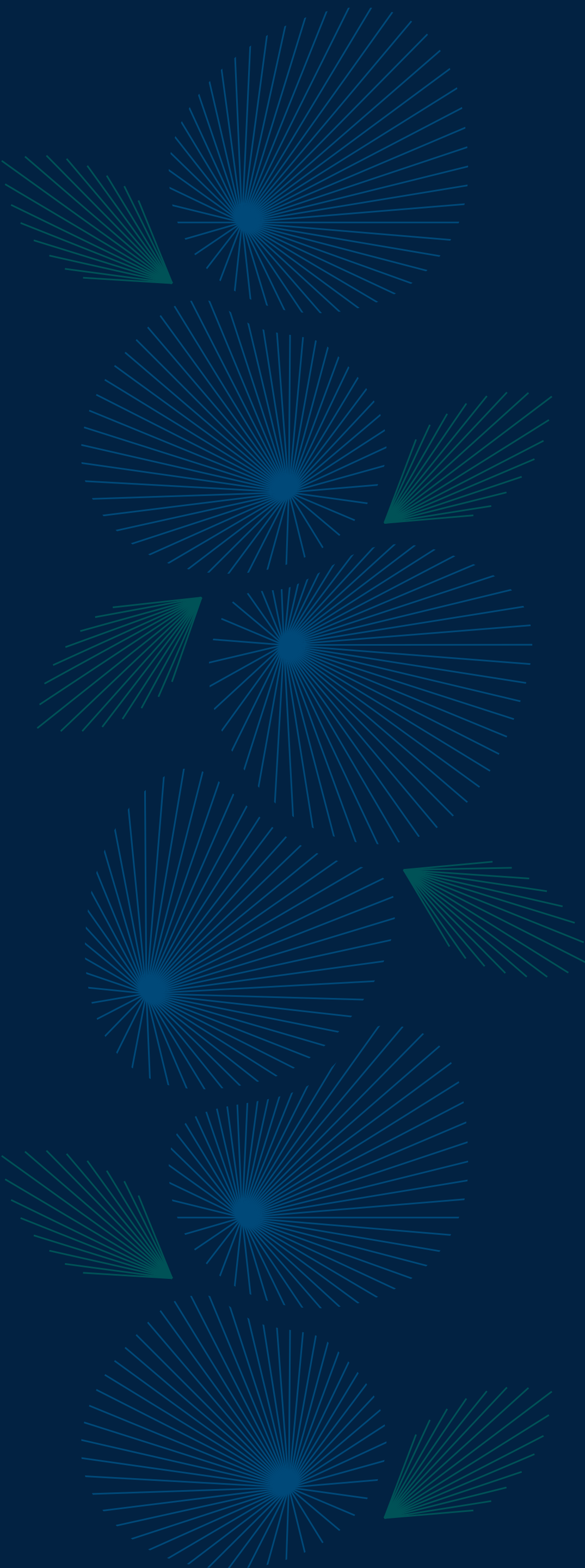

# TORRE 1



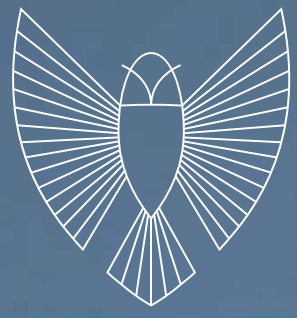

Torre 1 | Vista Norte







MODELO A

DESDE \$2,238,600.00 MXN



# Modelo A

## 54.60 m<sup>2</sup>

Áreas



1  
Recámara

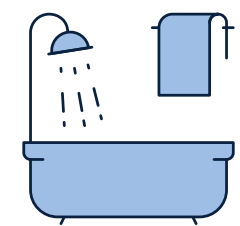

1 1/2  
Baños



Cocina Integral



Sala



Comedor

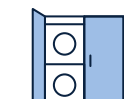

Clóset de Servicio



1 Cajón de  
Estacionamiento

Ubicación en Torre 1

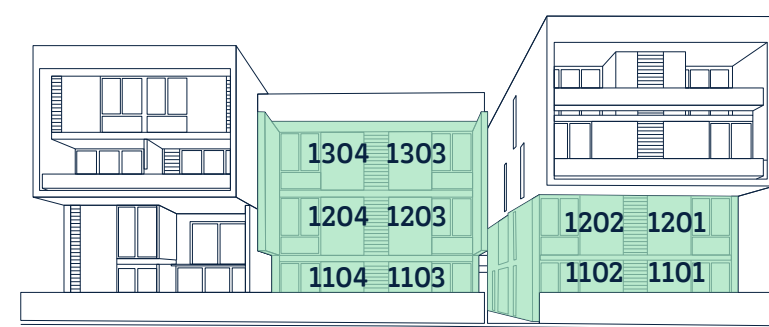

Fachada Norte



Fachada Sur

TOTAL | 239 departamentos

TORRE 1 | 12 departamentos





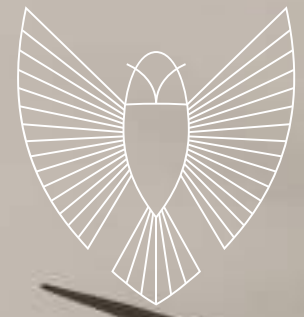

Modelo A | Sala - Comedor

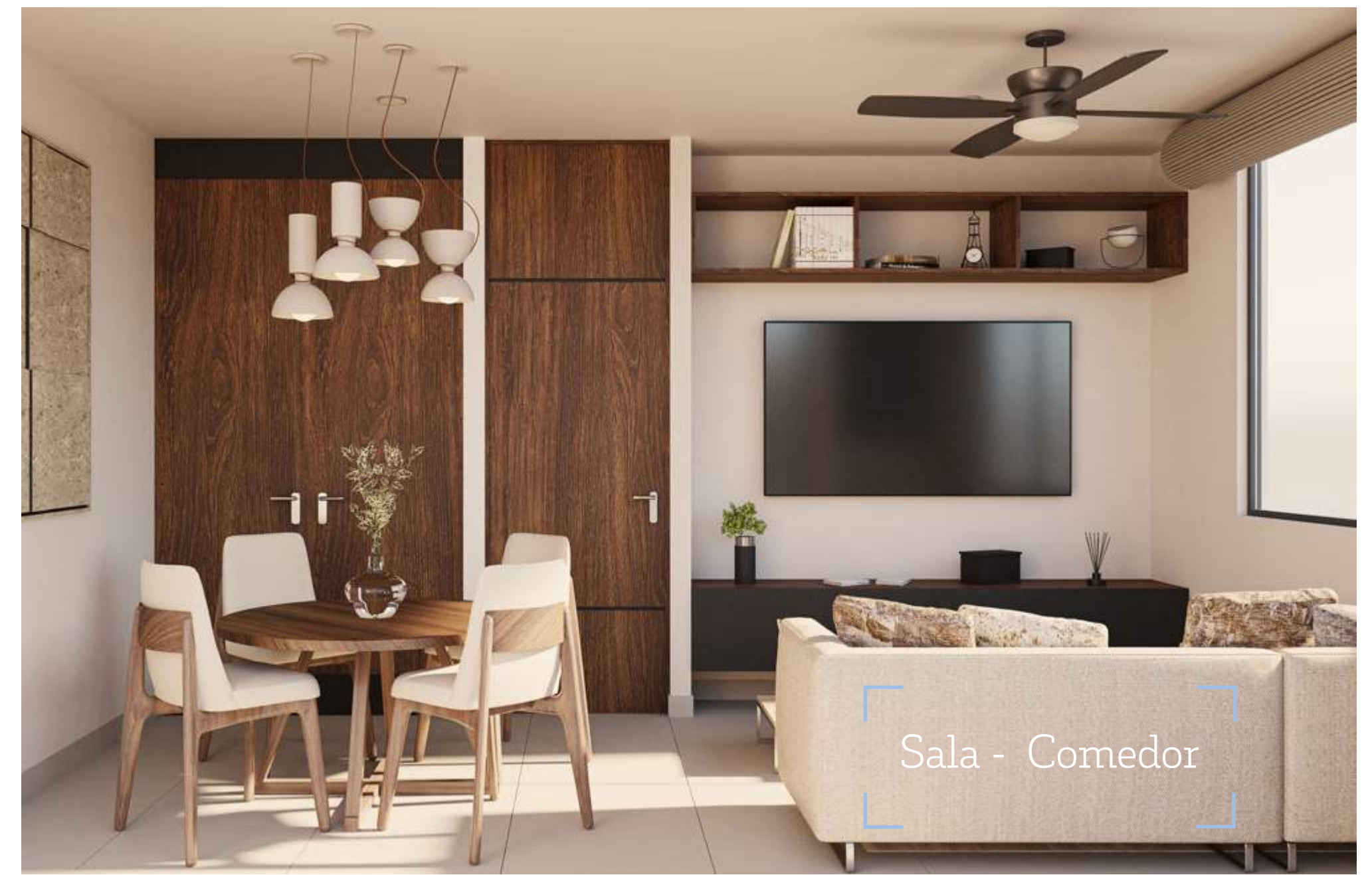
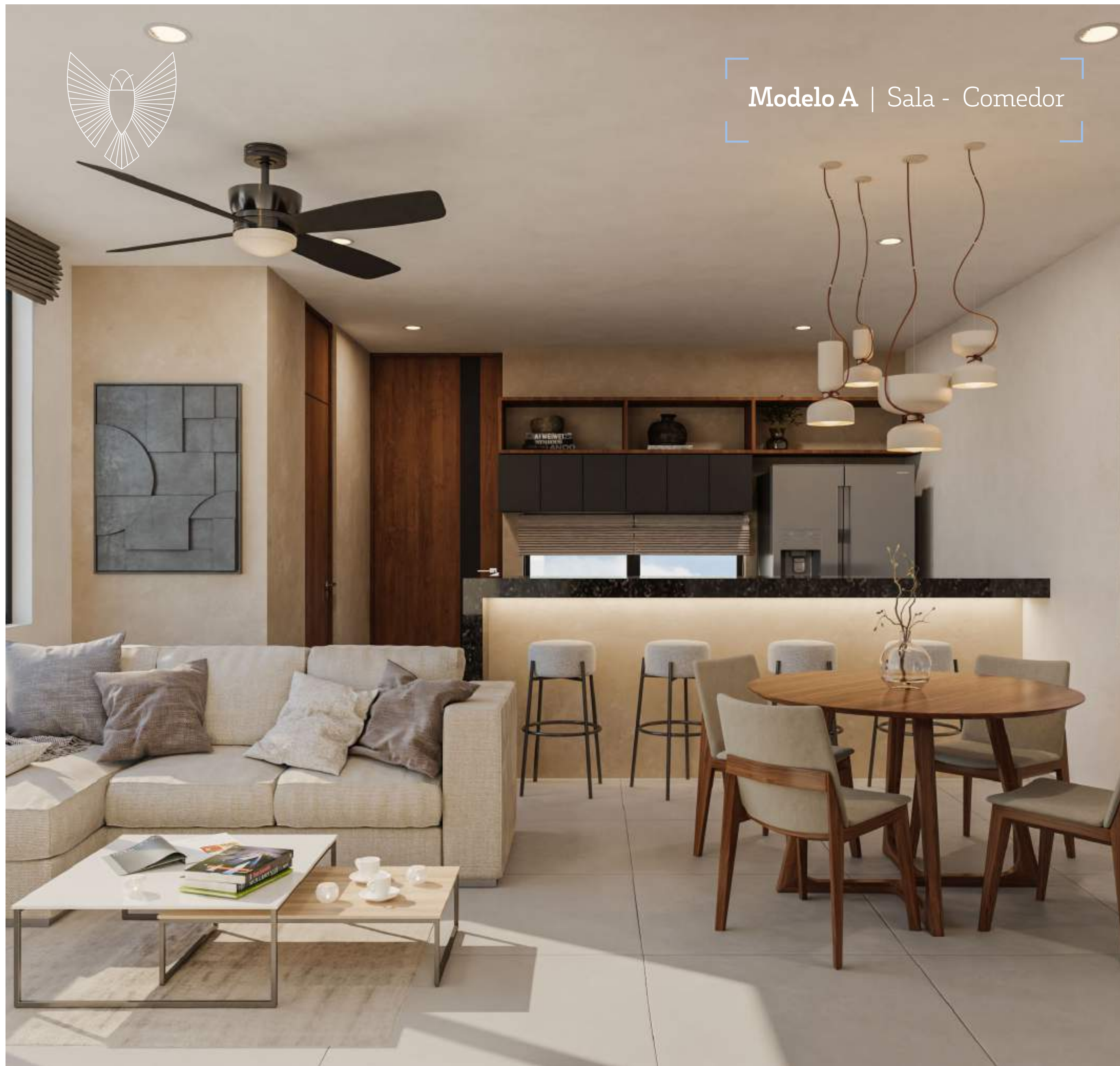

Sala - Comedor



Recámara





MODELO B

DESDE \$3,577,895.55<sup>MXN</sup>



# Modelo B

## 85.56 m<sup>2</sup>

Áreas



2  
Recámaras



2 1/2  
Baños



Cocina Integral



Sala



Comedor

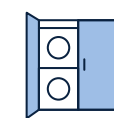

Clóset de Servicio



1 Cajón de Estacionamiento



Terraza en PB o Balcón en PA

Ubicación en Torre 1



Fachada Norte



Fachada Sur

TOTAL | 239 departamentos

TORRE 1 | 8 departamentos

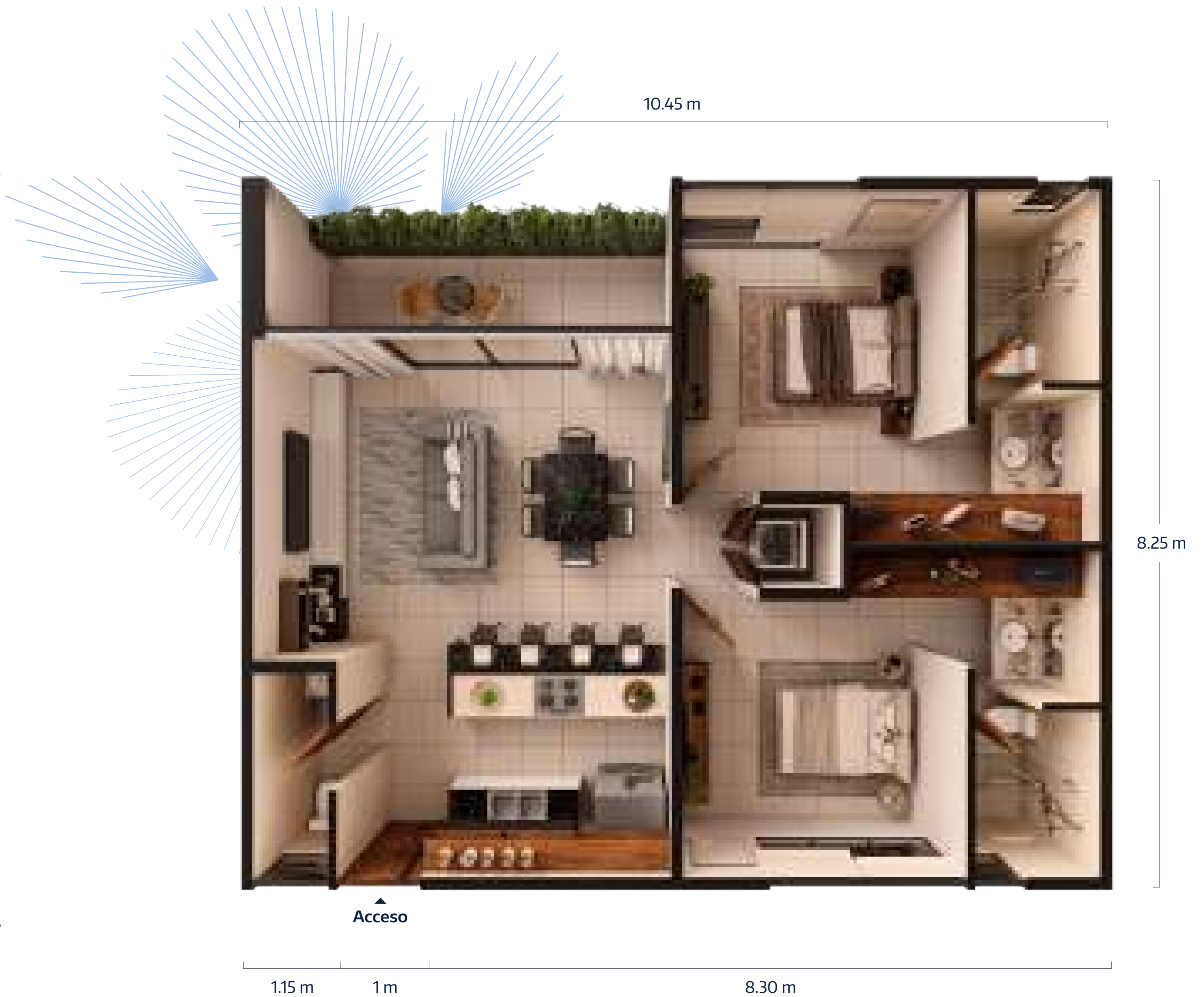



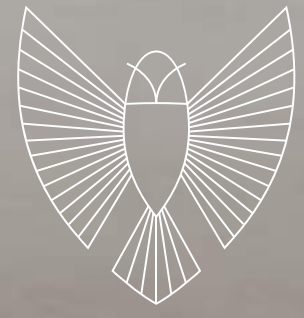

Modelo B | Sala - Comedor

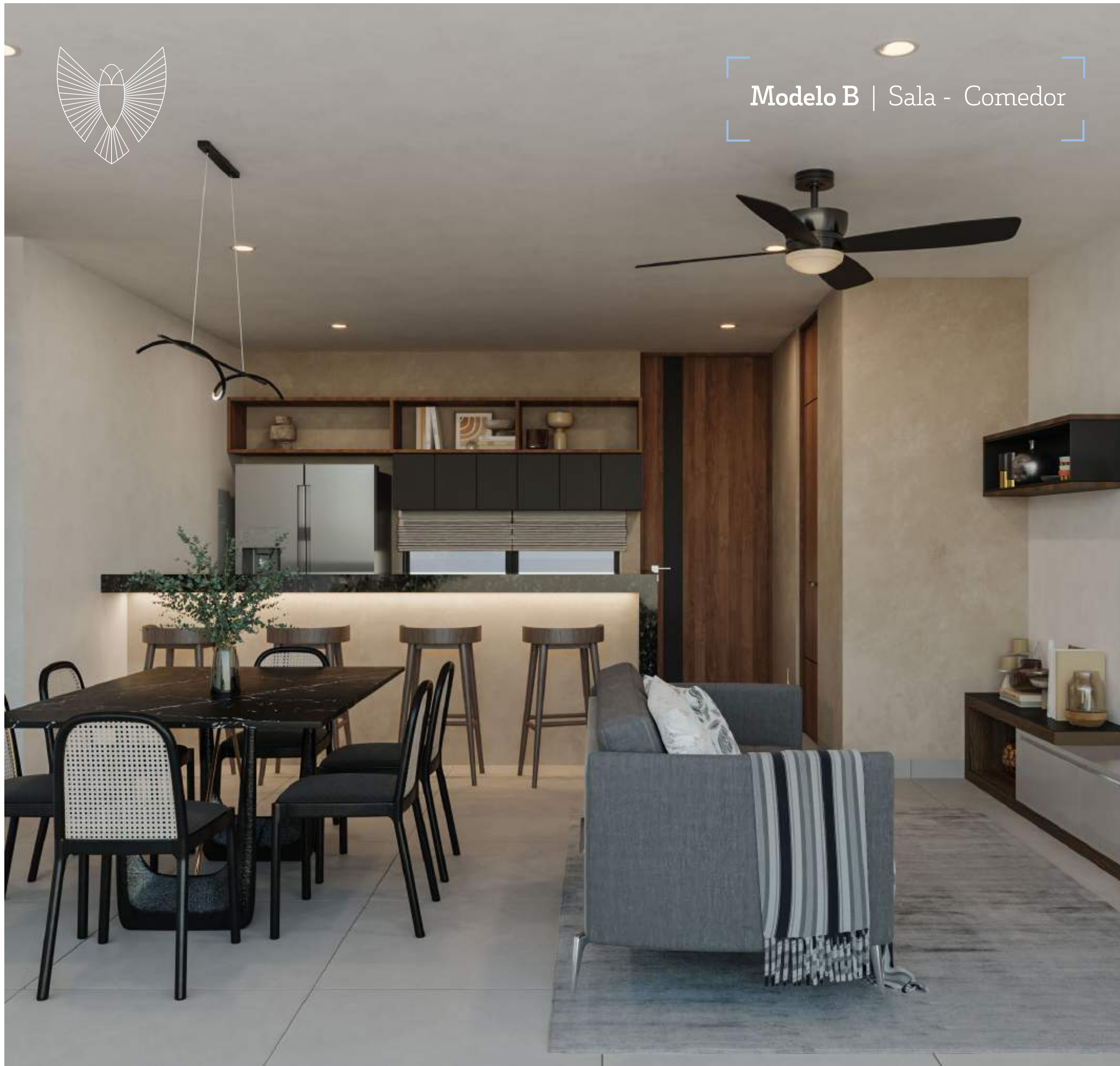

Recámara 1



Recámara 2





MODELO C

DESDE \$4,068,819.30<sup>MXN</sup>



# Modelo C

104.63 m<sup>2</sup>

## Áreas



2  
Recámaras

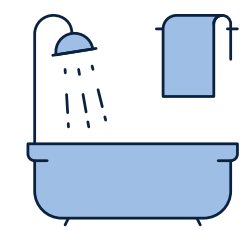

2 1/2  
Baños



Cocina Integral



Sala



Comedor

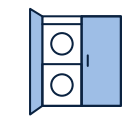

Clóset de Servicio



2 Cajones de Estacionamiento



Balcón

## Ubicación en Torre 1

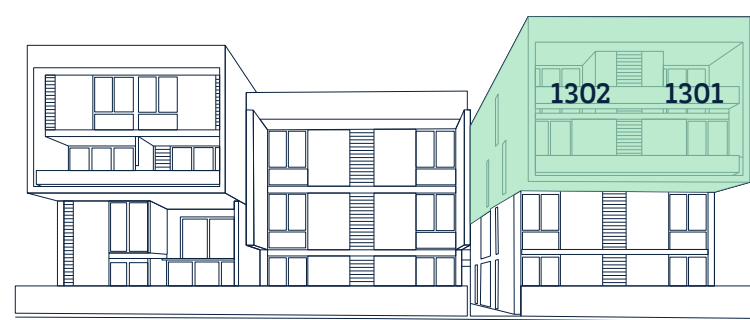

Fachada Norte



Fachada Sur

TOTAL | 239 departamentos

TORRE 1 | 3 departamentos

Planta Baja



Acceso

3.15 m

1 m

1.15 m

Planta Alta



12.15 m

5.30 m





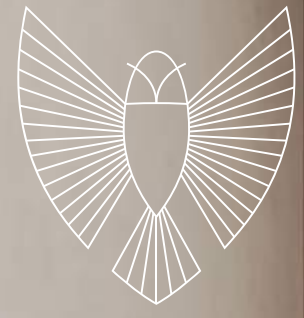

Modelo C | Sala - Comedor

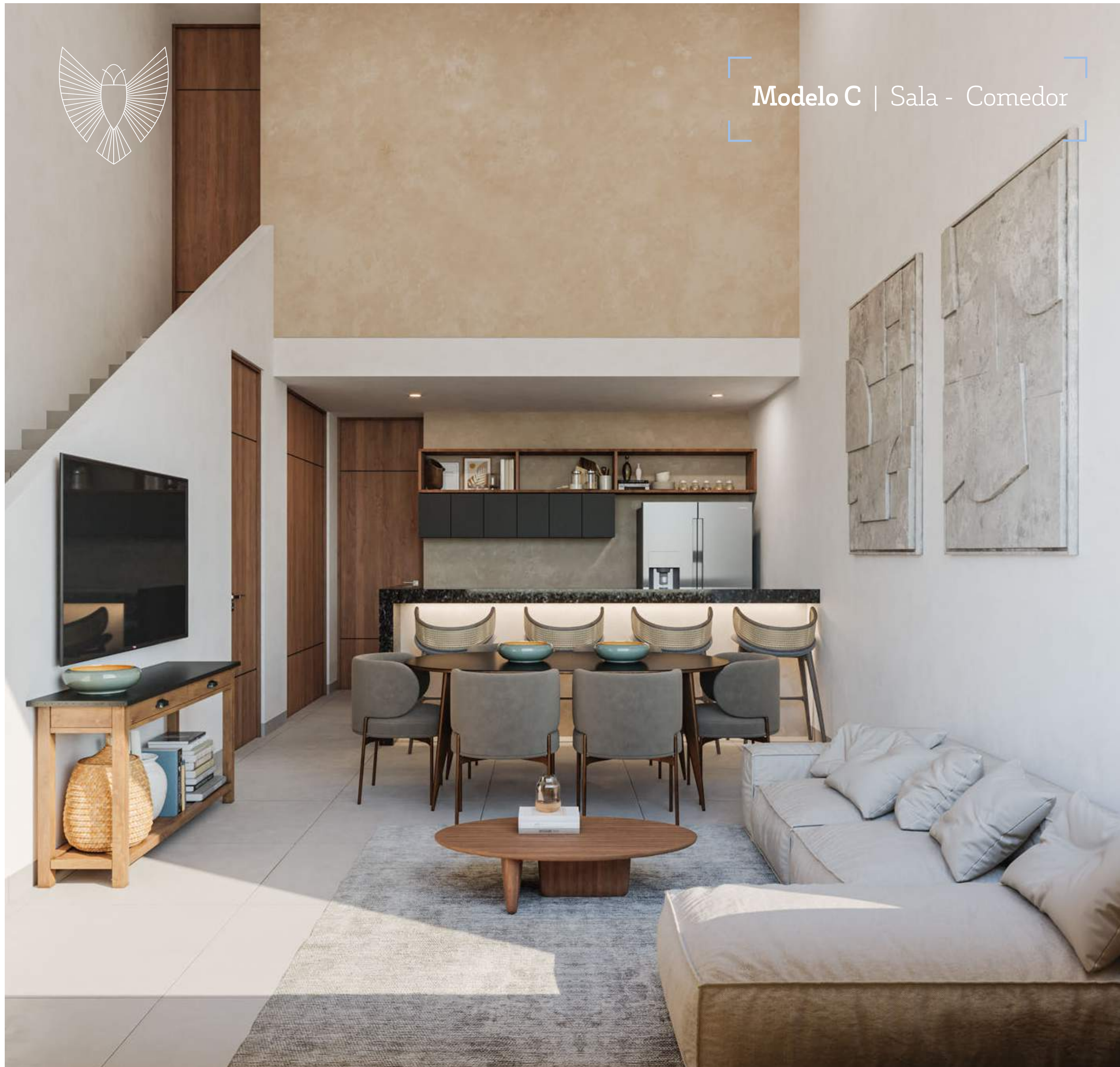

Recámara 1

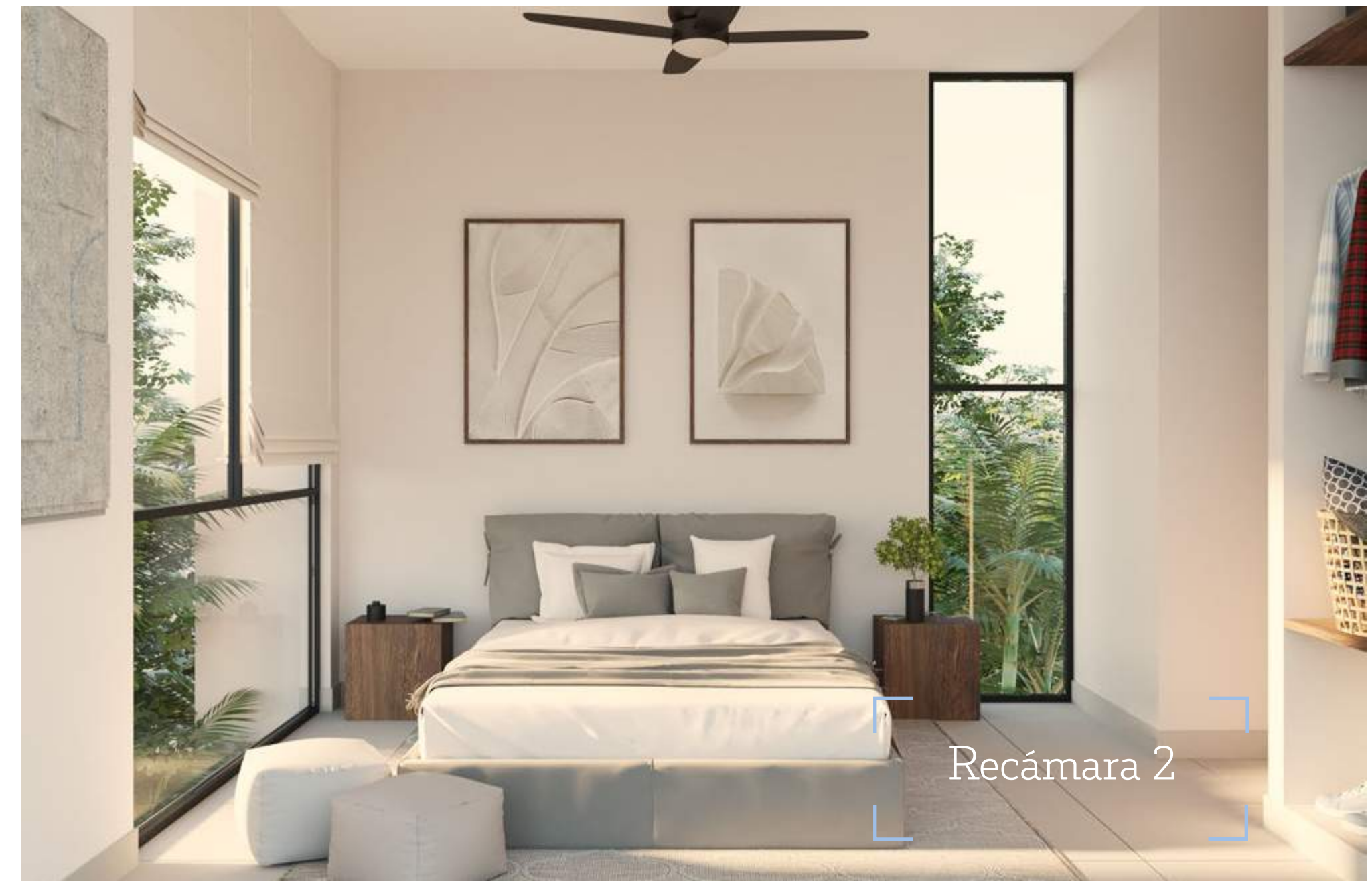

Recámara 2





MODELO D

DESDE \$4,188,746.66<sup>MXN</sup>



# Modelo D

## 101.29m<sup>2</sup>

### Áreas



2  
Recámaras



Cocina Integral



Sala



Comedor

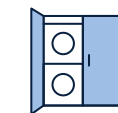

Clóset de Servicio



2 Cajones de Estacionamiento



Balcón

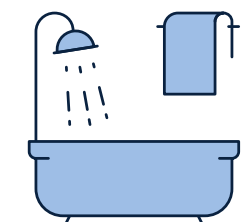

2 1/2  
Baños

### Ubicación en Torre 1

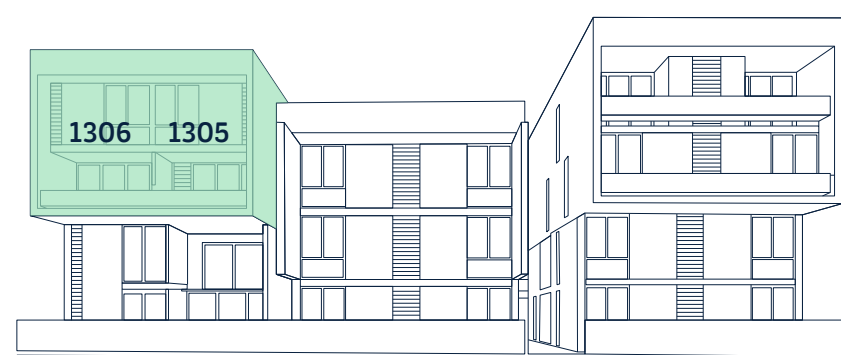

Fachada Norte



Fachada Sur

TOTAL | 239 departamentos

TORRE 1 | 8 departamentos

Planta Baja



Acceso

1.15 m 1 m 3.15 m

Planta Alta



9.25 m

5.30 m







Modelo D | Sala - Comedor

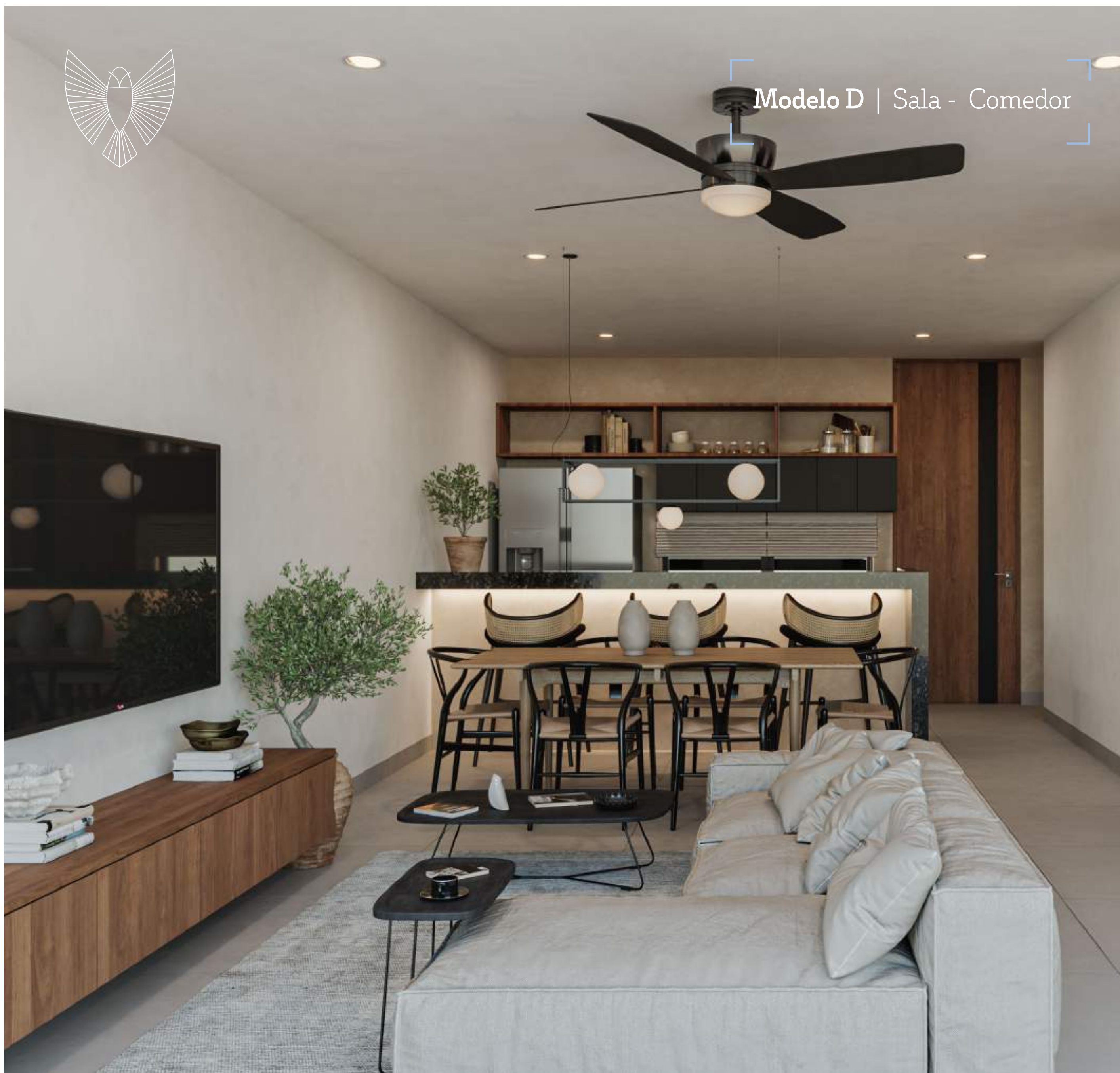

Recámara 1



Recámara 2



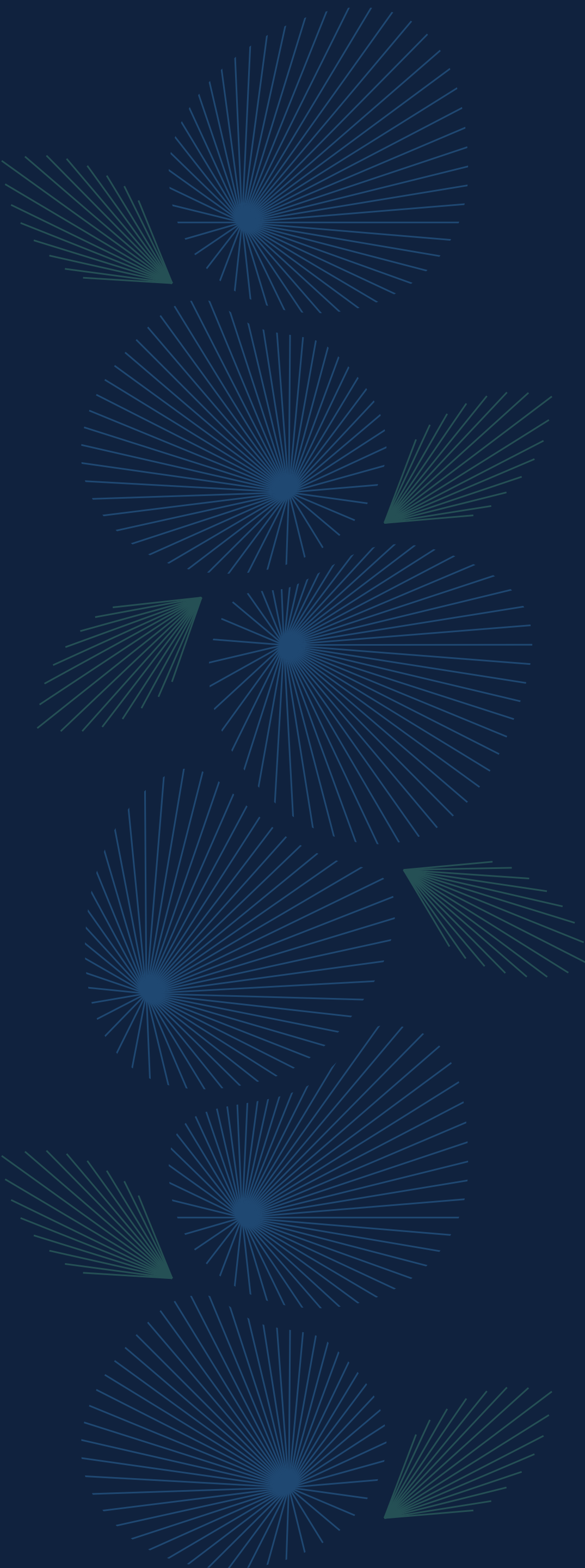

# CAJONES DE ESTACIONAMIENTO



# CAJONES DE ESTACIONAMIENTO

## TORRE 1

- Planta baja
- Primer nivel
- Segundo nivel
- Visita
- Venta

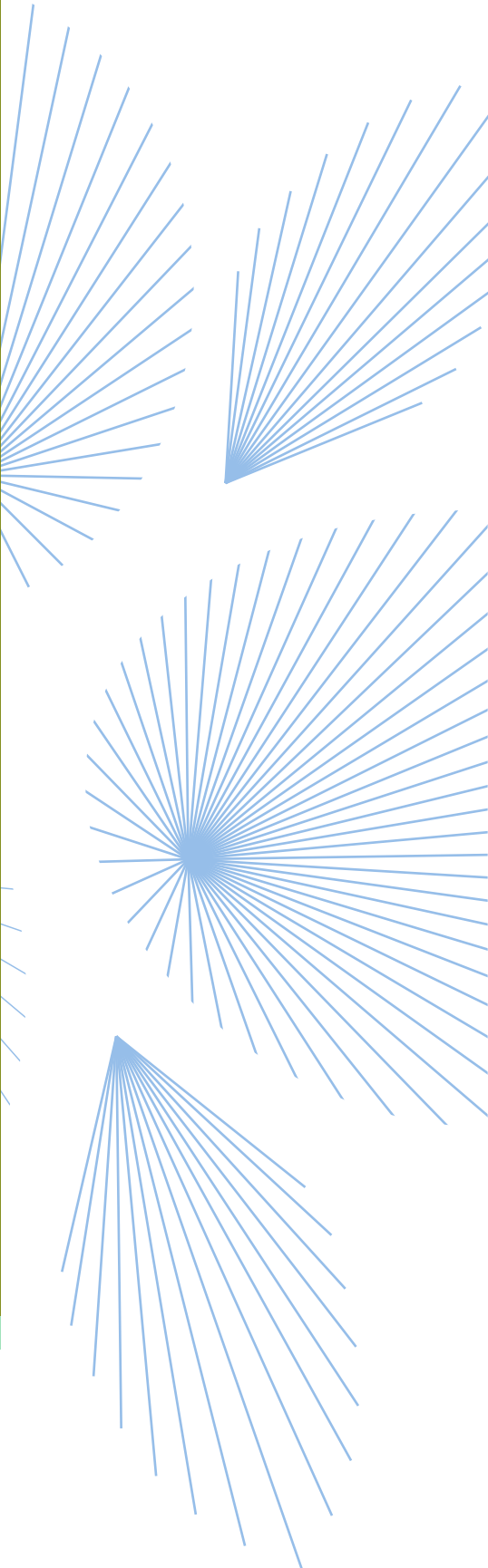
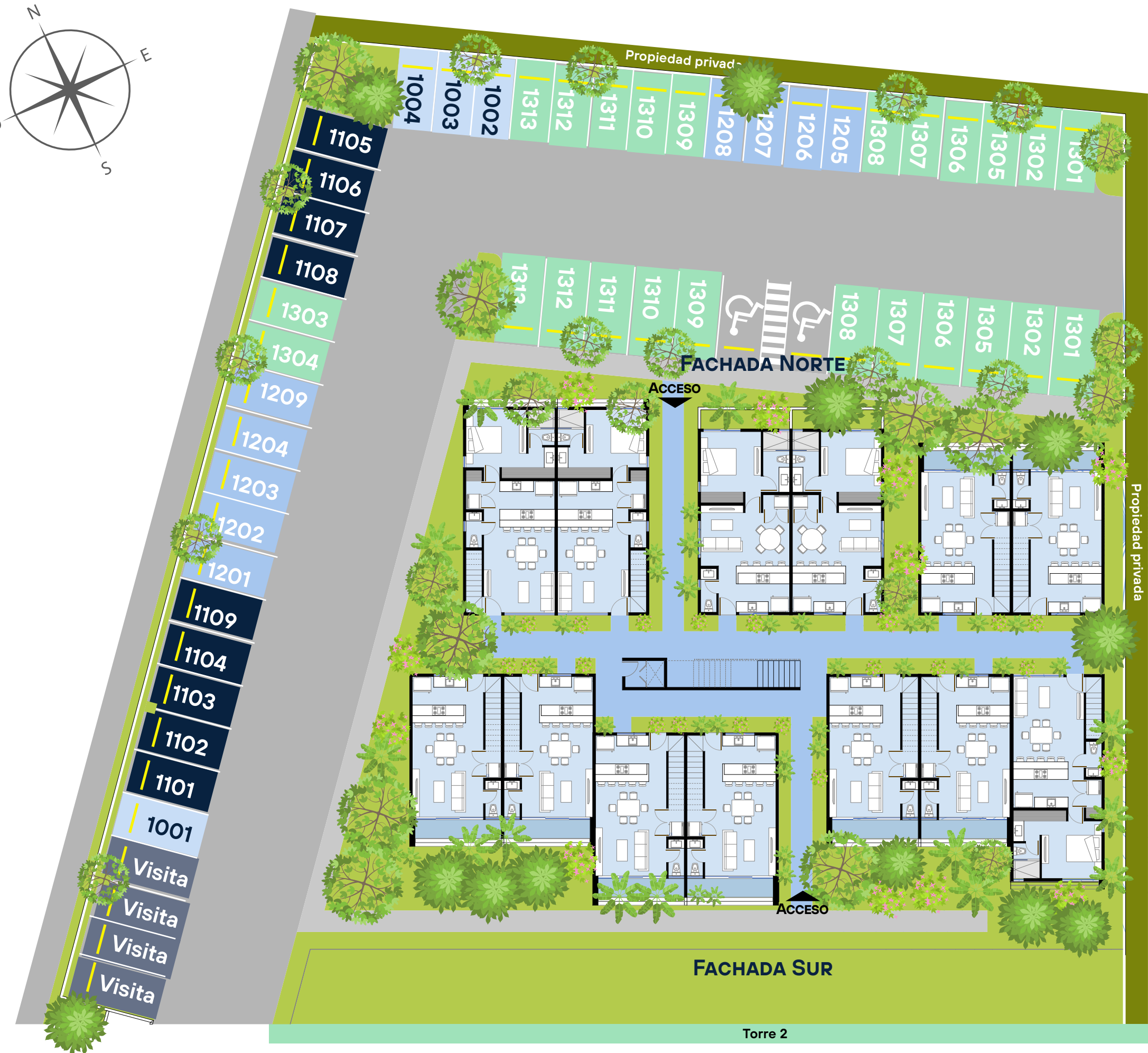
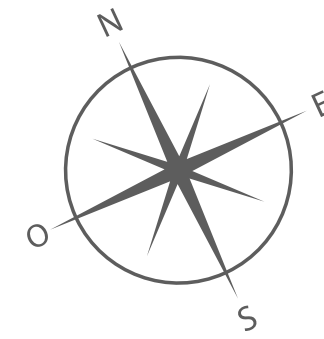



# PLANES DE FINANCIAMIENTO O R V E

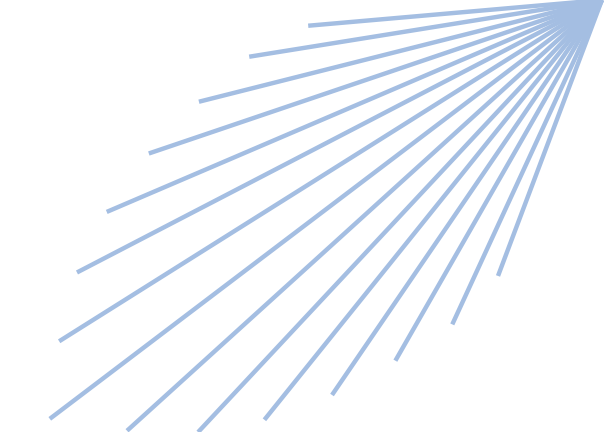

APARTA HOY CON

**\$10,000** MXN

ENGANCHE DEL **20%**

SALDO CONTRA ENTREGA

Se aplican restricciones. Entrega 2024.





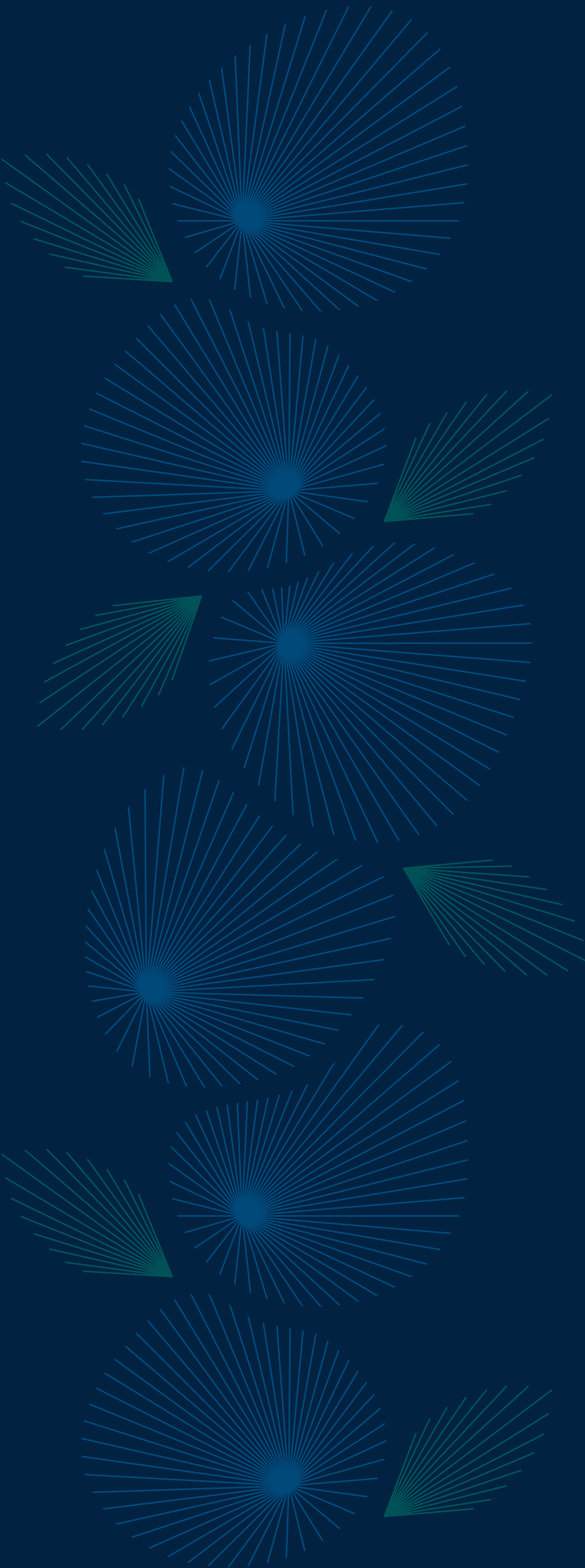

TORRE 2



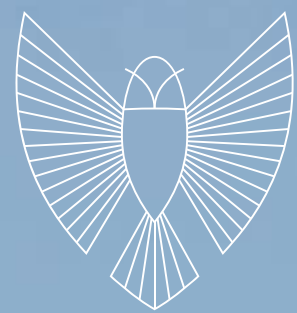

Torre 2 | Fachada Sur







MODELO A

DESDE \$2,244,340.00<sup>MXN</sup>













MODELO B

DESDE \$3,472,773.75<sup>MXN</sup>









Modelo B | Cocina - Comedor



Recámara 1

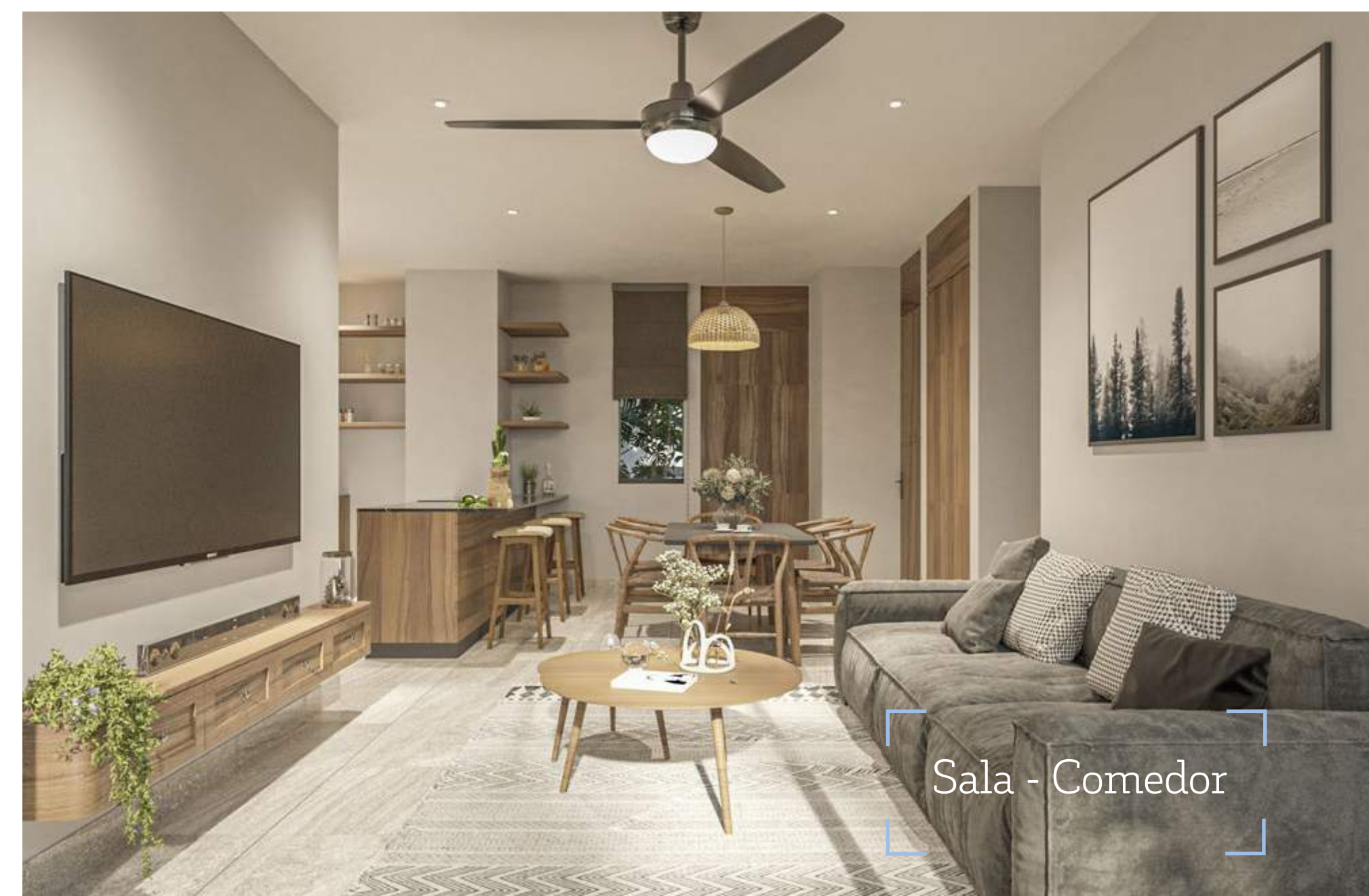

Sala - Comedor





MODELO C

DESDE \$2,202,100.50<sup>MXN</sup>



# Modelo C

54.80 m<sup>2</sup>

Áreas

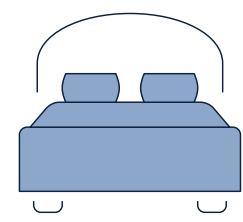

1  
Recámara

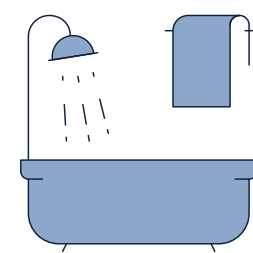

1 1/2  
Baños



Cocina Integral



Sala

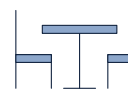

Comedor

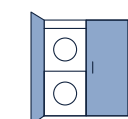

Clóset de Servicio



1 Cajón de Estacionamiento

Ubicación en Torre 2



Fachada Norte



Fachada Sur

TOTAL | 239 departamentos

TORRE 2 | 24 departamentos

Planta baja



2.3 m 1 m 2.52 m

Planta alta



3.75 m

9.10 m







Modelo C | Sala - Comedor

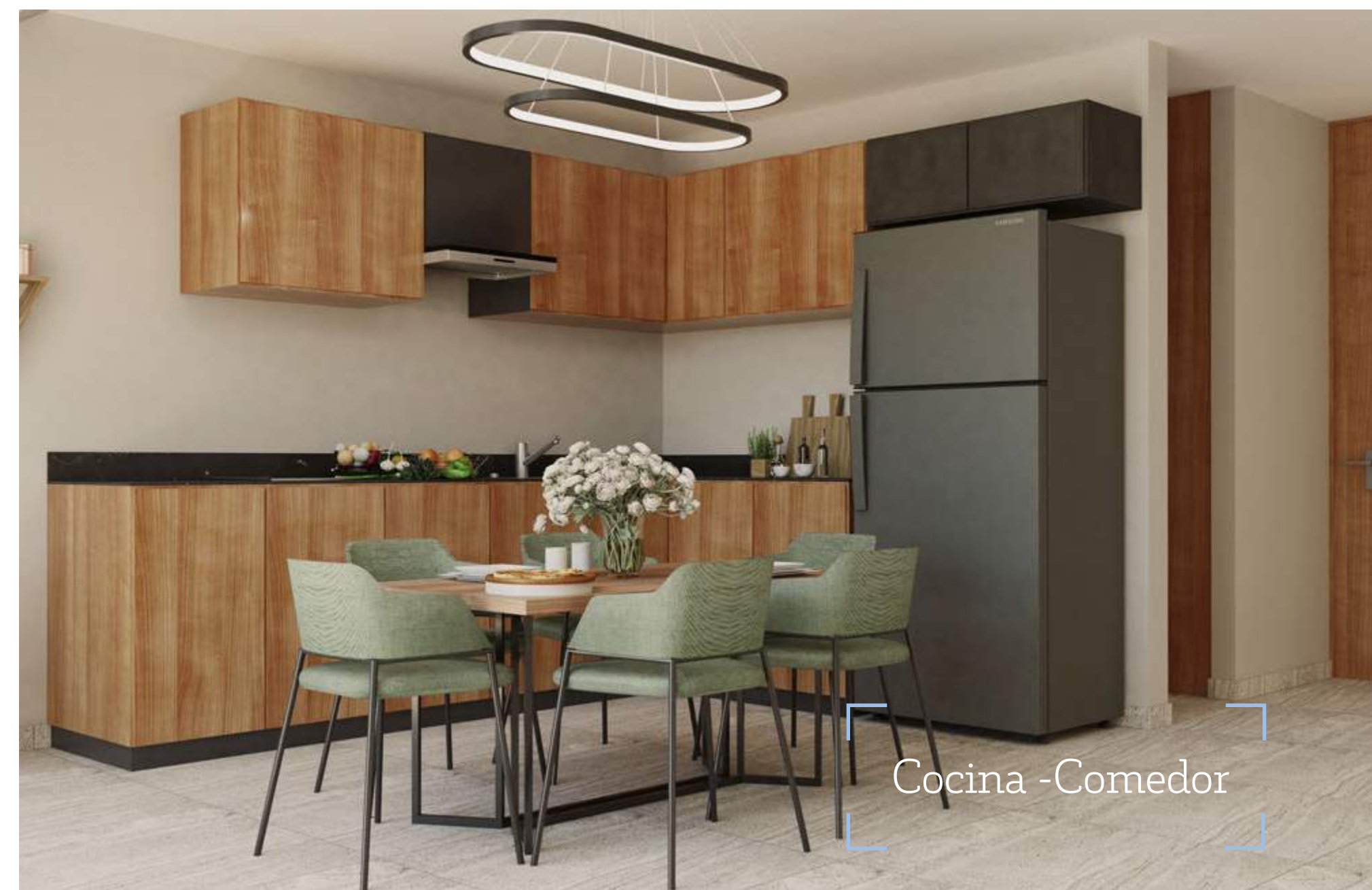

Cocina - Comedor



Recámara



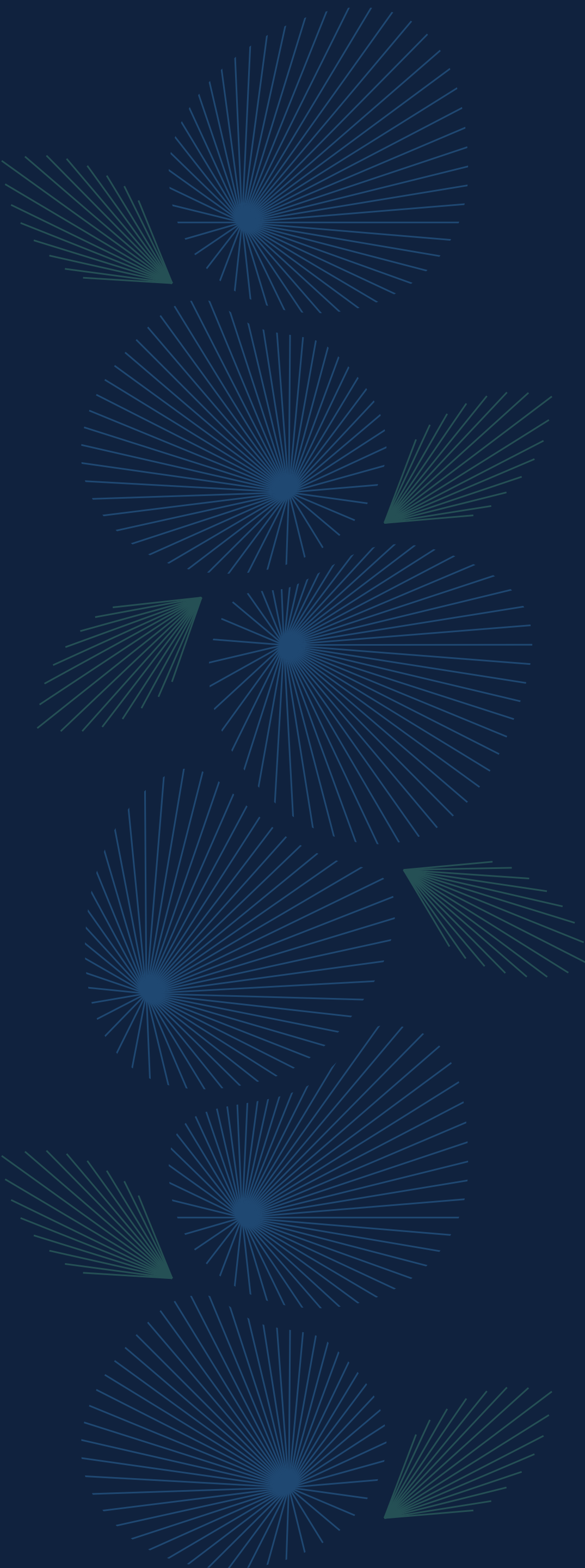

# CAJONES DE ESTACIONAMIENTO



# CAJONES DE ESTACIONAMIENTO

## TORRE 2

- Planta baja
- Primer nivel
- Segundo nivel
- Tercer nivel
- Cuarto nivel
- Venta
- Visita





# PLANES DE FINANCIAMIENTO O R V E

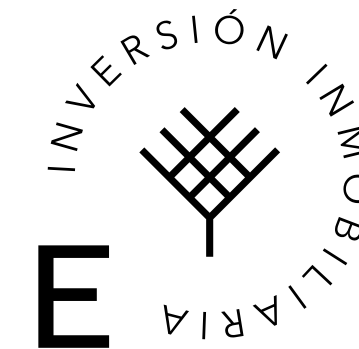

APARTA HOY CON  
**\$10,000** MXN

ENGANCHE DEL **20%**  
SALDO CONTRA ENTREGA

Se aplican restricciones. Entrega 2025

